

# Screed pump PMX 35

# ATMOS



# technical specifications

Model	PMX 35
Engine	Perkins 404D-22
Displacement	2216 cm <sup>3</sup>
Full load speed	2600 min. <sup>-1</sup>
Compressor	B100
Receiver	260 L
Fuel Tank	70 L
Transport distance	up to 200 meters
Transport altitude	up to 50 meters
Grain size	up to 16mm diameter
Chassis	Knott
Max Length	4200 mm
Overall width	1480 mm
Height	1320 mm
Weight	1490 kg

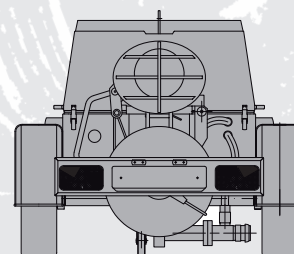
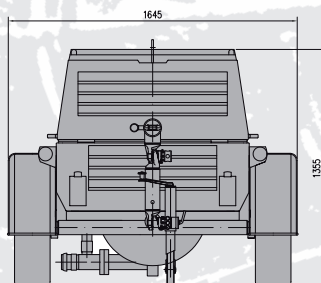
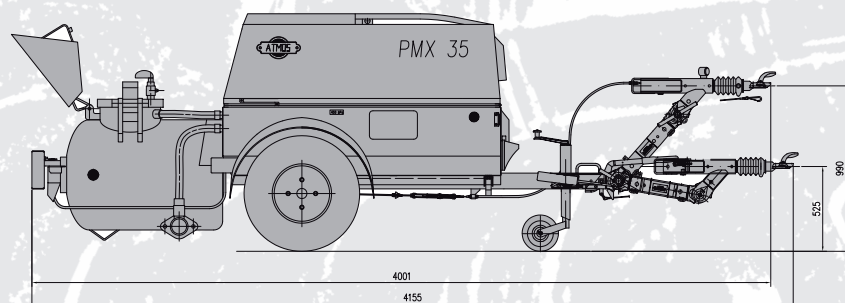

ATMOS reserve the right to change the models and/or specification without prior notice.



ATMOS Chrást, s.r.o.  
[www.atmos-chrast.com](http://www.atmos-chrast.com)  
[info@atmos-chrast.cz](mailto:info@atmos-chrast.cz)

Export Manager - Phone: +420 377 860 161  
 Export Manager - Phone: +420 377 860 413  
 Fax: +420 377 945 379

Plzeňská 149, 330 03 Chrást u Plzně  
 Czech Republic